

NOTE:
Please read all
instructions carefully
before using this product

Table of Contents

Safety Notice

Important Assembly
Information

Care and Maintenance

Parts List

Warranty

Ordering Parts

Model
SB-228C

Retain This
Manual for
Reference

180430

**OWNER'S
MANUAL**



MARCY®

MARCY® Multi Purpose Bench SB-228C

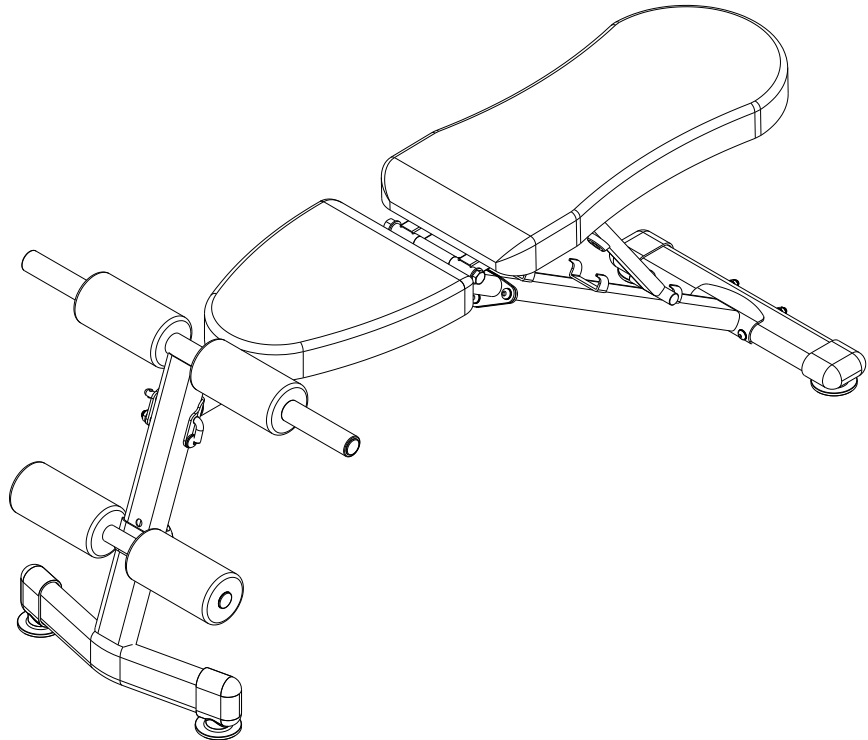

IMPORTANT: Please read this manual before commencing
assembly of this product.

IMPEX® INC.

2801 S. Towne Ave, Pomona, CA 91766

Tel: 800- 999-8899

www.marcypro.com

support@impex-fitness.com

TABLE OF CONTENTS

BEFORE YOU BEGIN	1
IMPORTANT SAFETY NOTICES	2
EXERCISE GUIDELINES	3
WARNING LABEL PLACEMENT	5
FREE AND TRAINING AREA	6
IMPORTANT ASSEMBLY INFORMATION	7
WEIGHT CAPACITY AND DIMENSION	8
CARE AND MAINTENANCE	8
HARDWARE IDENTIFIER	9
ASSEMBLY INSTRUCTIONS	10
EXPLODED DIAGRAM	15
PARTS LIST	16
WARRANTY	17
ORDERING PARTS	17

BEFORE YOU BEGIN

Thank you for selecting the MARCY SB-228C Multi-Purpose Bench by IMPEX® INC. For your safety and benefit, read this manual carefully before using the machine. As a manufacturer, we are committed to provide you complete customer satisfaction. If you have any questions, or find there are missing or damaged parts, we guarantee you complete satisfaction through direct assistance from our factory. To avoid unnecessary delays, *please call our TOLL-FREE customer service number.* Our Customer Service Agents will provide immediate assistance to you.

Toll-Free Customer Service Number

1-800-999-8899

Mon. - Fri. 9 a.m. - 5 p.m. PST

www.marcypro.com

support@impex-fitness.com

IMPORTANT SAFETY NOTICE

This exercise equipment is built for optimum safety. However, certain precautions apply whenever you operate a piece of exercise equipment. Be sure to read the entire manual before you assemble or operate your equipment. In particular, note the following safety precautions:

1. **Keep children and pets away from the equipment at all times. DO NOT leave children unattended in the same room with the equipment.**
2. Only one person at a time should use the equipment.
3. If the user experiences dizziness, nausea, chest pain, or any other abnormal symptoms, STOP the workout at once. CONSULT A PHYSICIAN IMMEDIATELY.
4. Position the equipment on a clear, leveled surface. DO NOT use the equipment near water or outdoors.
5. Keep hands away from all moving parts.
6. Always wear appropriate workout clothing when exercising. DO NOT wear robes or other clothing that could become caught in the equipment. Running or aerobic shoes are also required when using the equipment.
7. Use the equipment only for its intended use as described in this manual. DO NOT use attachments not recommended by the manufacturer.
8. Do not place any sharp object around the equipment.
9. Disabled persons should not use the equipment.
10. Before using the equipment to exercise, always do stretching exercises to properly warm up.
11. Never operate the equipment if the equipment is not functioning properly.
12. A spotter is recommended during exercise.
13. **This equipment is designed and intended for home and consumer use only, not for commercial use.**

WARNING: BEFORE BEGINNING ANY EXERCISE PROGRAM, CONSULT YOUR PHYSICIAN. THIS IS ESPECIALLY IMPORTANT FOR INDIVIDUALS OVER THE AGE OF 35 OR PERSONS WITH PRE-EXISTING HEALTH PROBLEMS. READ ALL INSTRUCTIONS BEFORE USING ANY FITNESS EQUIPMENT. IMPEX INC. ASSUMES NO RESPONSIBILITY FOR PERSONAL INJURY OR PROPERTY DAMAGE SUSTAINED BY OR THROUGH THE USE OF THIS PRODUCT.

SAVE THESE INSTRUCTIONS.

EXERCISE GUIDELINES

Building Muscle and Gaining Weight

Unlike aerobic exercise, which emphasizes endurance training, anaerobic exercise focuses on strength training. A gradual weight gain can occur while building the size and strength of muscles. While developing muscle mass, your body adapts to the stress placed upon it. You can modify your diet to include foods such as meat, fish and vegetables. These foods help muscles recover and replenish important nutrients after a strenuous workout.

Muscle Strength and Endurance

To achieve the greatest benefit from exercise, it is important to develop an exercise program that allows you to work all of the major muscle groups equally.

To increase muscle strength, follow this principle:

Increasing resistance and maintaining the number of repetitions of an exercise results in increased muscle strength.

To tone your body, follow this principle: Decreasing resistance plus increasing the number of repetitions of an exercise results in increased body tone.

Once you feel comfortable with an exercise, you can change the resistance, the number of repetitions, or the speed at which you do the exercise. It is not necessary to change all three variables. For example, let's say that you are training at 23 kg (50 lb.) and performing the exercise 10 times in 3 minutes. When this becomes too easy, you may decide to move up to lifting 27 kg (60 lb.) for the same number of repetitions in the same amount of time. Lifting more weights fewer times most often develops muscle strength. To gain both muscle strength and endurance, it is recommended that you perform each exercise 15 to 20 reps per set.

Training Intensity

How hard you begin to train depends on your overall level of fitness. The soreness you experienced can be lessened by decreasing the load you place on your muscles and by performing fewer sets. To avoid injury, you should gradually work into an exercise program and set the load to your individual fitness level. The load should increase as your fitness level increases.

Muscle soreness is common, especially when you first start exercising. If you are painfully sore for a long time, it may be time to change your program. Eventually, your muscle system will become accustomed to the stress and strain placed on it.

Beginning a Strength Building Program

Warming Up

To begin strength training, it is important to stretch and perform light exercise for 5 to 10 minutes. This helps prepare the body for more strenuous exercise by increasing circulation, raising your body temperature and developing more oxygen to your muscles.

Workout

For each workout, to keep in mind that muscle soreness that lasts for a long period is not desirable and may mean that injury has occurred.

Cool Down

At the end of each workout, perform slow stretching exercises for 5 to 10 minutes. Ease into each stretch only going as far as you can. This stage allows your muscles to wind down after training.

To provide a total workout program it is also recommended that 2 to 3 days of aerobic exercise is performed in addition to the strength training.

Drinking Water

For the body to function properly, it must be properly hydrated. If you are exercising, you should increase your fluid intake. The reason for this is that the water you take in will leave your system through the sweating mechanism that cools your body during exercise. The water you lose through exercise must be replaced so that the muscles can recover properly.

Rest Day

Although you may not feel like doing it, taking a rest day at least once a week is important because it gives your body a chance to heal itself. Continuously working your muscles will result in over- training, which will not benefit you in the long run.

WARNING LABEL PLACEMENT

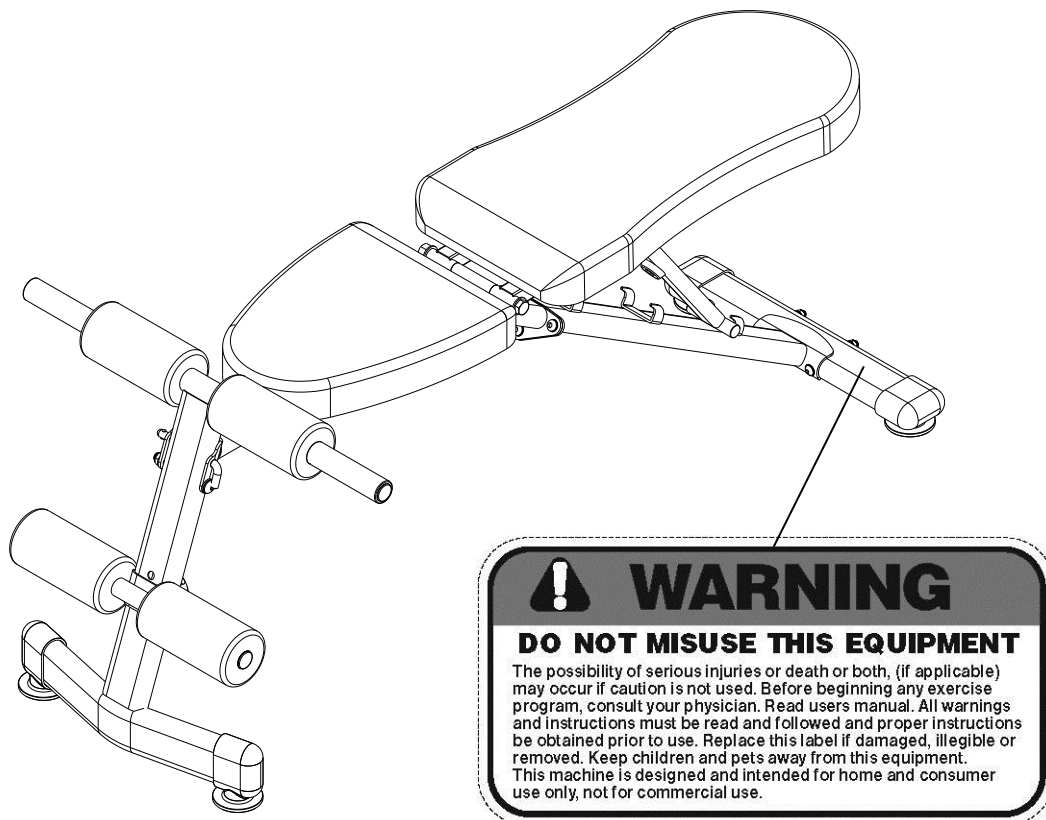

**The Warning Label shown here has been placed on the Rear Base.
If the label is missing or illegible, please call customer service at 1-800-999-8899 for replacement.
Apply the label in the location shown.**

FREE AND TRAINING AREA

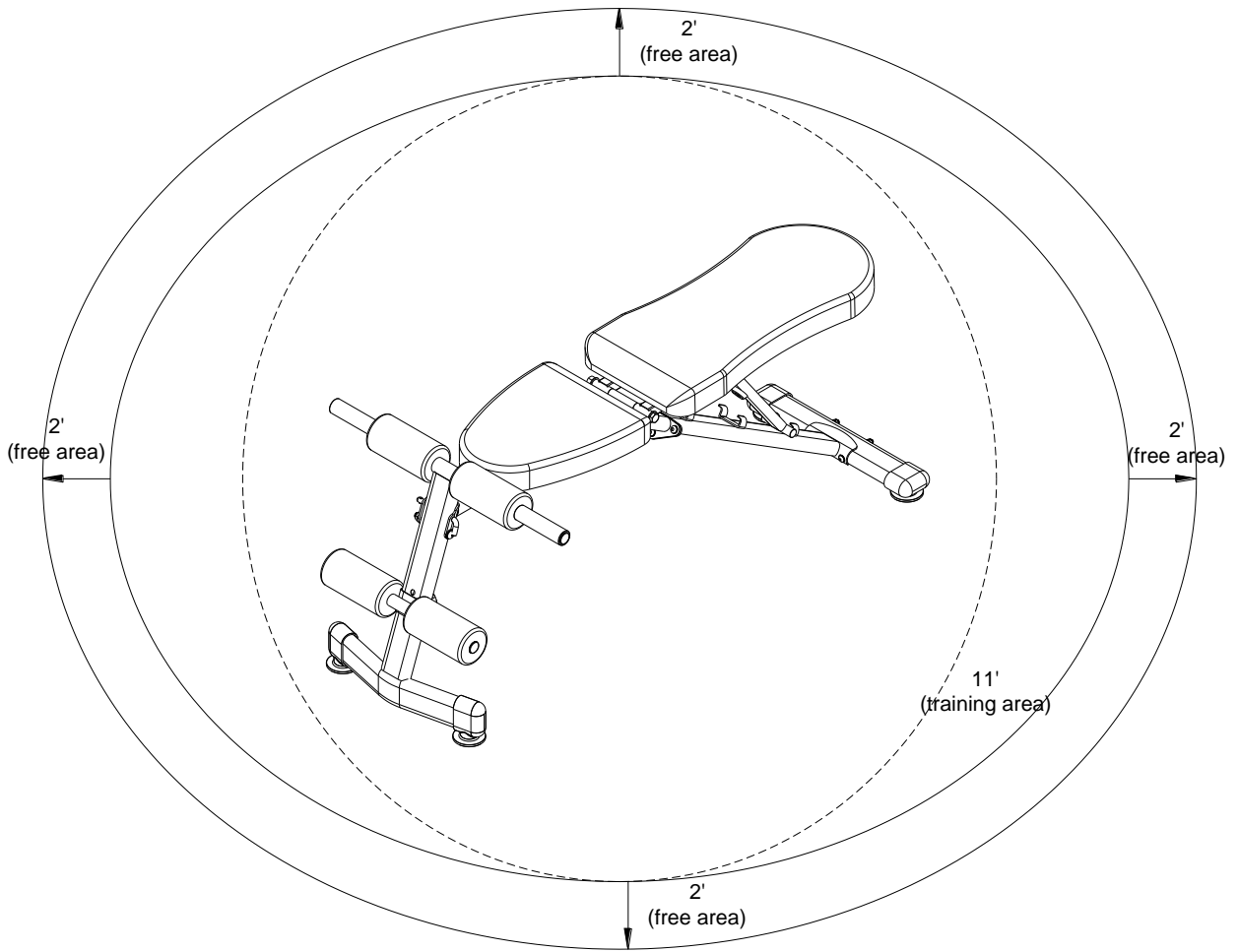

IMPORTANT ASSEMBLY INFORMATION

- ❖ Tools required for assembling the bench: Two adjustable Wrenches and Allen wrenches.
- ❖ NOTE: It is strongly recommended that this equipment be assembled by two or more people to avoid possible injury.
- ❖ Ensure **Carriage Bolts** are inserted through the **SQUARE holes** on components that need to be assembled. Attach washer only to end of the Carriage Bolt.
- ❖ Use **Allen Bolts or Hex Bolts** inserted through the **ROUND hole** on components that need to be assembled.
- ❖ Always wait until all bolts are assembled onto the bench before tightening the bolts. Do not tighten each bolt right after it is installed

Fasten Nuts and Bolts

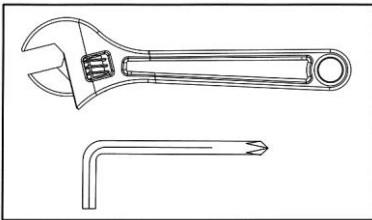

Securely tighten all nuts and bolts after all components have been assembled in current and previous steps.

NOTE: Do not over-tighten any component with pivoting function.

Make sure all pivoting components are able to move freely.

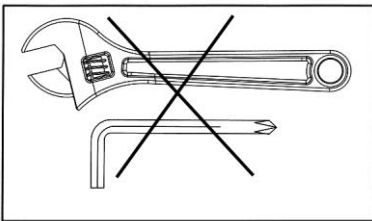

Do not tighten all nuts and bolts in this step.

WEIGHT CAPACITY AND DIMENSION

1. Maximum user weight: 300 lbs.
2. Bench assembled dimensions: 51.2" × 25.4" × 41.9"

CARE AND MAINTENANCE

1. Lubricate moving parts with WD-40 or light oil periodically.
2. Inspect and tighten all parts before using the equipment.
3. The equipment can be cleaned using a damp cloth and mild non-abrasive detergent.
DO NOT use solvents.
4. Examine the equipment regularly for signs of damage or wear.
5. Replace any defective components immediately and/or keep the equipment out of use until repair.
6. **Failure to examine regularly may affect the safety level of the equipment.**

HARDWARE PACK

NOTE: The following parts are not drawn to scale. Please use your own ruler to measure the size.



#20 L-shaped Lock Pin(Qty 1)

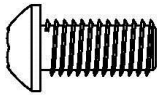

#25 M8×3/4" Allen Bolt(Qty 5)

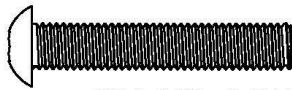

#24 M8×1 3/4" Allen Bolt(Qty 5)

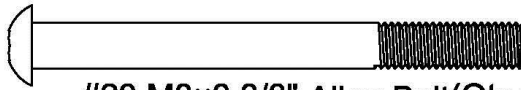

#23 M8×3 3/8" Allen Bolt(Qty 3)

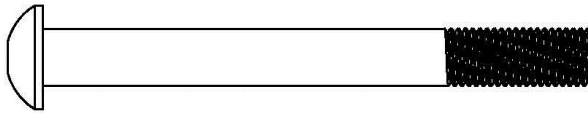

#22 M10×3 3/4" Allen Bolt(Qty 1)

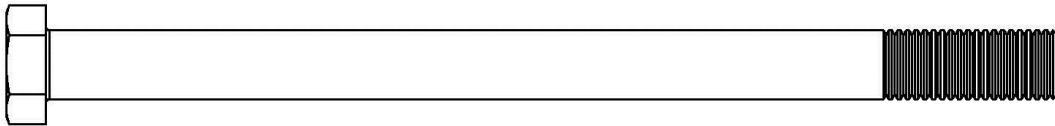

#21 M12×6 7/8" Hex Bolt(Qty 1)

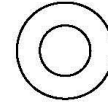

#30 Ø5/8" Washer (Qty 17)

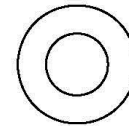

#29 Ø3/4" Washer (Qty 2)

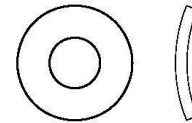

#27 Ø3/4"×R1" Washer (Qty 2)



#28 M8 Aircraft Nut (Qty 6)

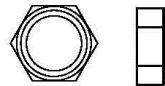

#32 M10 Aircraft Nut (Qty 1)

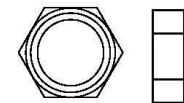

#31 M12 Aircraft Nut (Qty 1)

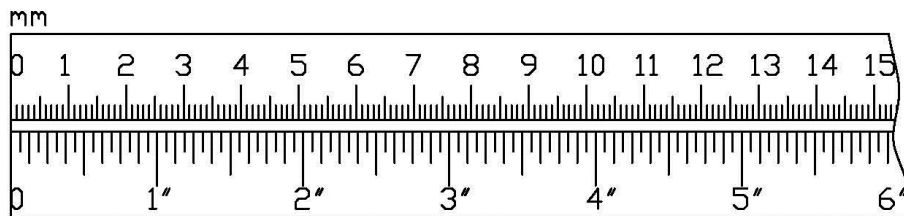

ASSEMBLY INSTRUCTION

Tools Required Assembling the Machine: Adjustable Wrench and Allen Wrench

NOTE: It is strongly recommended two or more people assembling this machine to avoid possible injuries.

STEP 1 (See Diagram 1)

A.) Attach the Main Frame (#3) to the Lower Main Frame (#1). Secure it with three M8 x 3/4" Allen Bolts (#25), six Ø 5/8" Washers (#30) and three M8 Aircraft Nuts (#28).

DIAGRAM 1

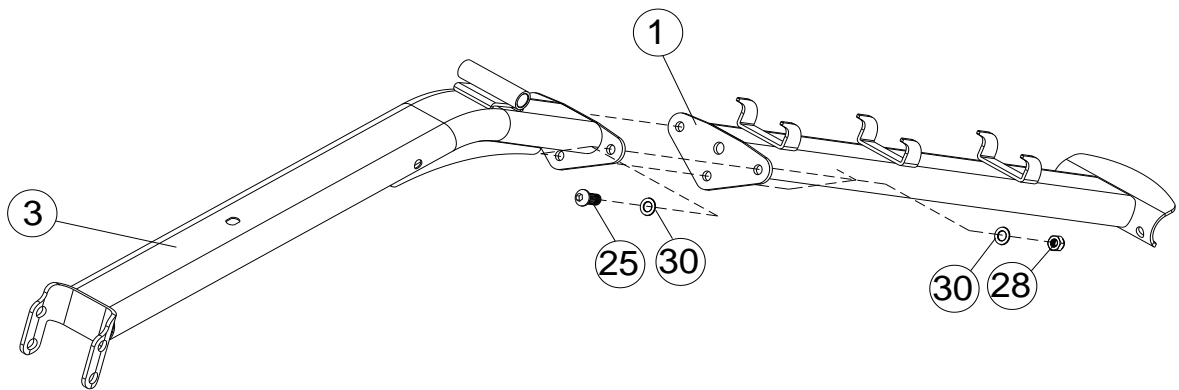

STEP 2 (See Diagram 2)

- A. Push the two Front Stabilizer End Caps (#13) and two Rear Stabilizer End Caps (#12) onto the Front Vertical Frame (#4) and the Rear Stabilizer (#2) from both ends.
- B. Attach the Lower Main Frame (#1) to the **Rear Stabilizer (#2)**. **Secure it with two M8 x 3 3/8" Allen Bolts (#23), two Ø 5/8" Washers (#30), two Ø 3/4" x R1" Washers (#27) and two M8 Aircraft Nuts (#28)**.
- C. Attach the Main Frame (#3) to the Front Vertical Frame (#4). Secure the lower hole with one M10 x 3 3/4" **Allen Bolt (#22), two Ø 3/4" Washers (#29), and one M10 Aircraft Nut (#32)**. Insert a L-shaped Lock Pin (#20) through the upper hole to lock the Front Vertical Frame (#4) in position. Remove the Pin when folding the bench for storage.

DIAGRAM 2

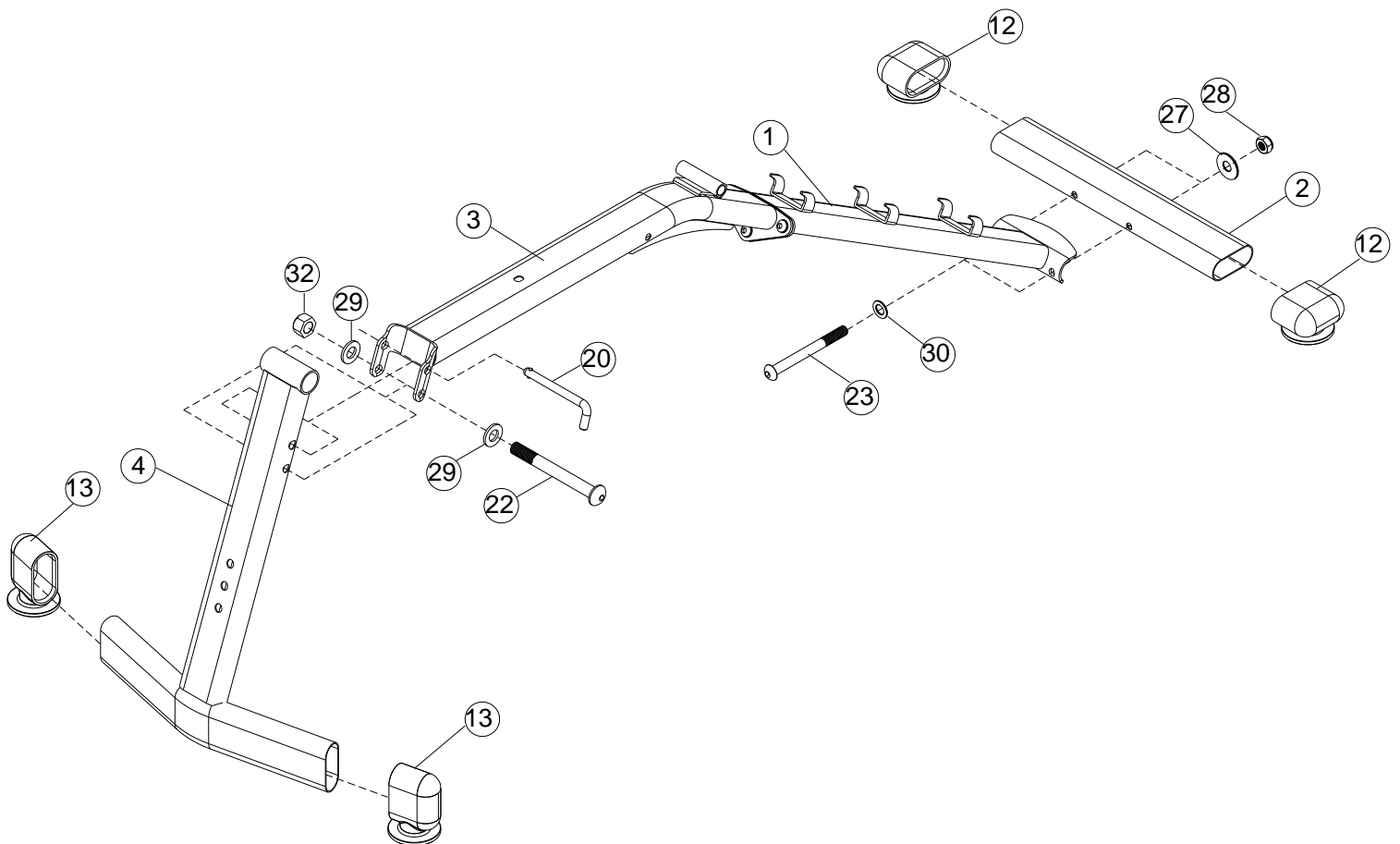

STEP 3 (See Diagram 3)

- A. Attach the Incline Support (#6) in between the two Backrest Supports (#5).
- B. Attach the Pivot of the Backrest Supports (#5) to the Pivot on the Main Frame (#3). Secure them with one M12 x 6 7/8" Hex Bolt (#21) and M12 Aircraft Nut (#31).
- C. Attach two L-shaped Brackets (#9) to the Main Frame (#3). Secure them with one M8 x 3 3/8" Allen Bolt (#23), two Ø 5/8" Washers (#30), and one M8 Aircraft Nut (#28).

DIAGRAM 3

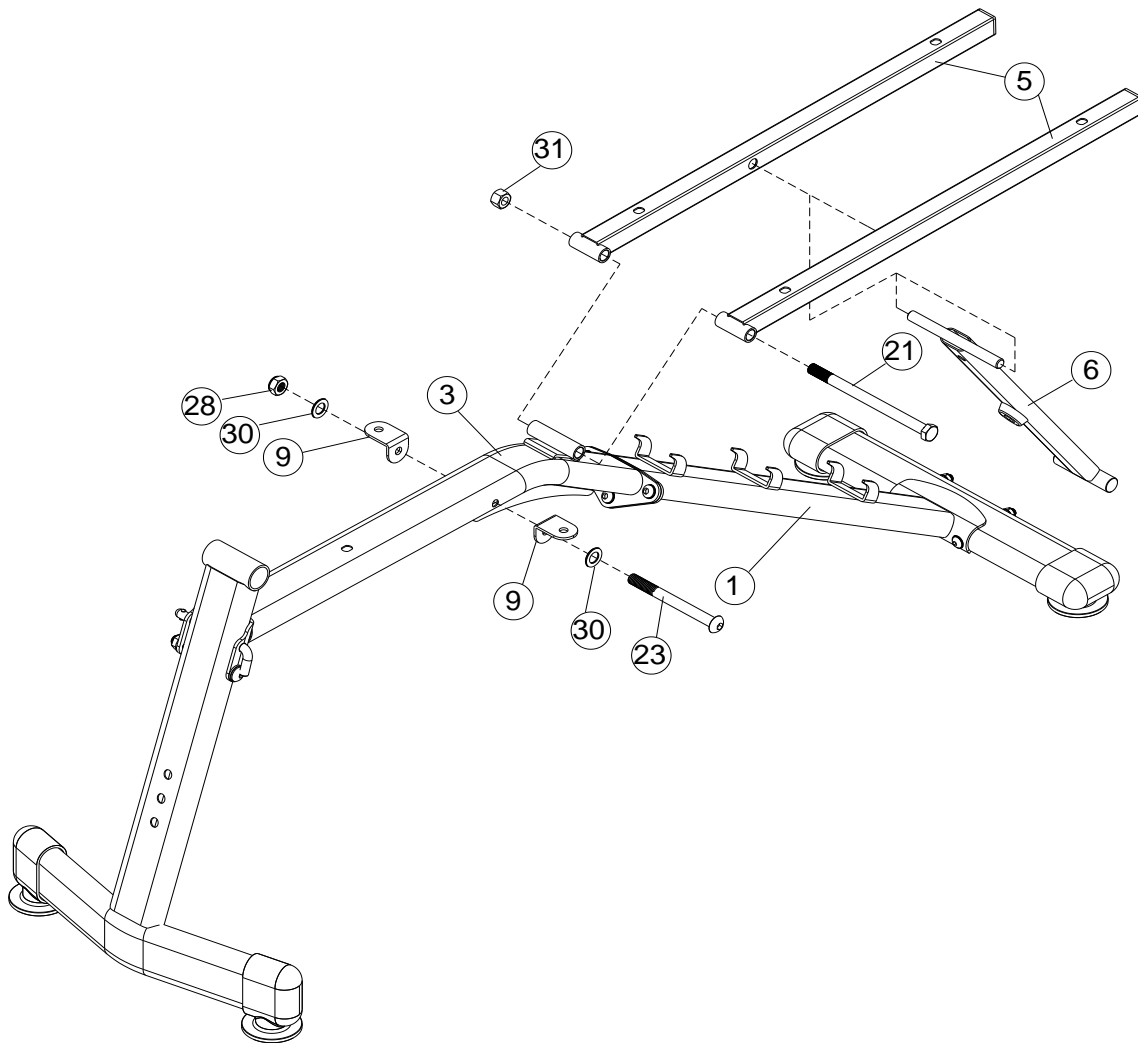

STEP 4 (See Diagram 4)

- A. Place the Seat (#10) onto the Main Frame (#3). Secure it to the two L-shaped Brackets (#9) with two M8 x 3/4" Allen Bolts (#25) and Ø 5/8" Washers (#30). Secure the Seat to the Main Frame with one M8 x 1 3/4" Allen Bolt (#24) and Ø 5/8" Washer (#30).
- B. Place the Backrest Board (#11) onto the Backrest Supports (#5). Secure it with four M8 x 3/4" Allen Bolts (#24) and Ø 5/8" Washers (#30).

DIAGRAM 4

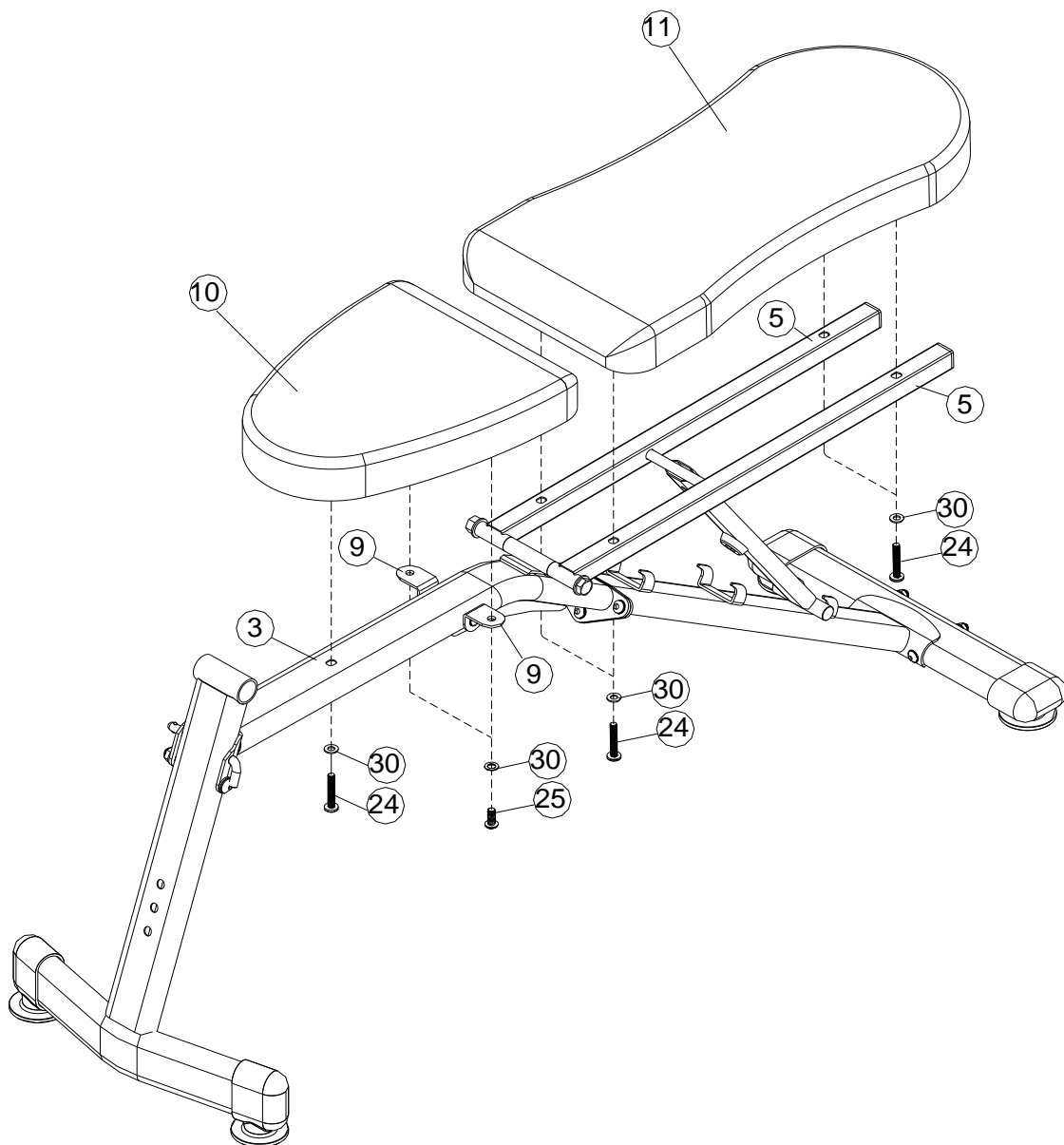

STEP 5 (See Diagram 5)

- A. Attach the Cross Tube (#7) to the Front Vertical Frame (#4). Use a Lock Knob (#16) to secure the Tube at selected hole on the Frame.
- B. Insert the Foam Tube (#8) halfway through the hole on the Front Vertical Frame (#4). Push four Vinyl Foam Rolls (#14) onto the Tubes.
- C. Lubricate the inside of the Foam Grips (#15) with dish soap. Slide the Foam Grips onto the Foam Tube (#8) from both sides.

DIAGRAM 5

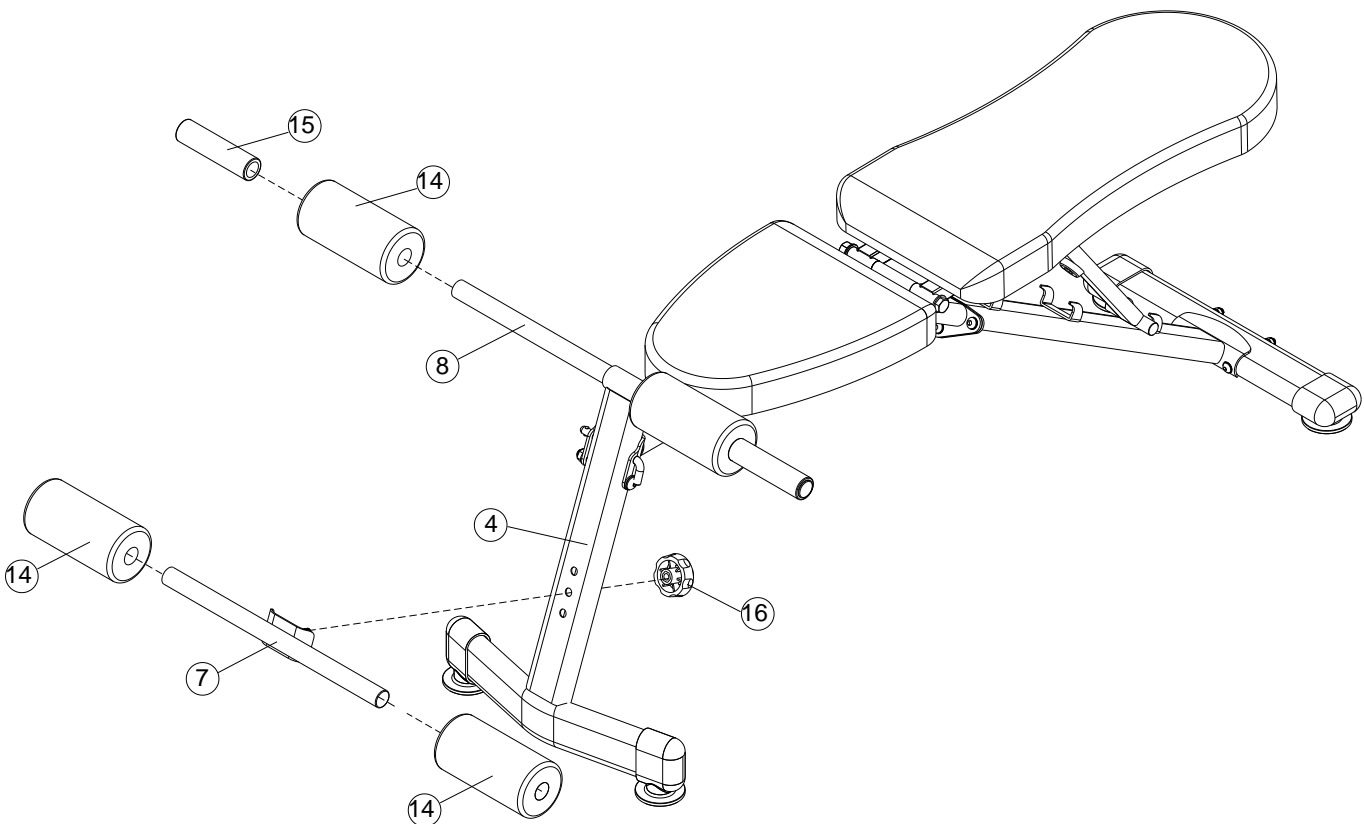

SB-228C EXPLODED DIAGRAM

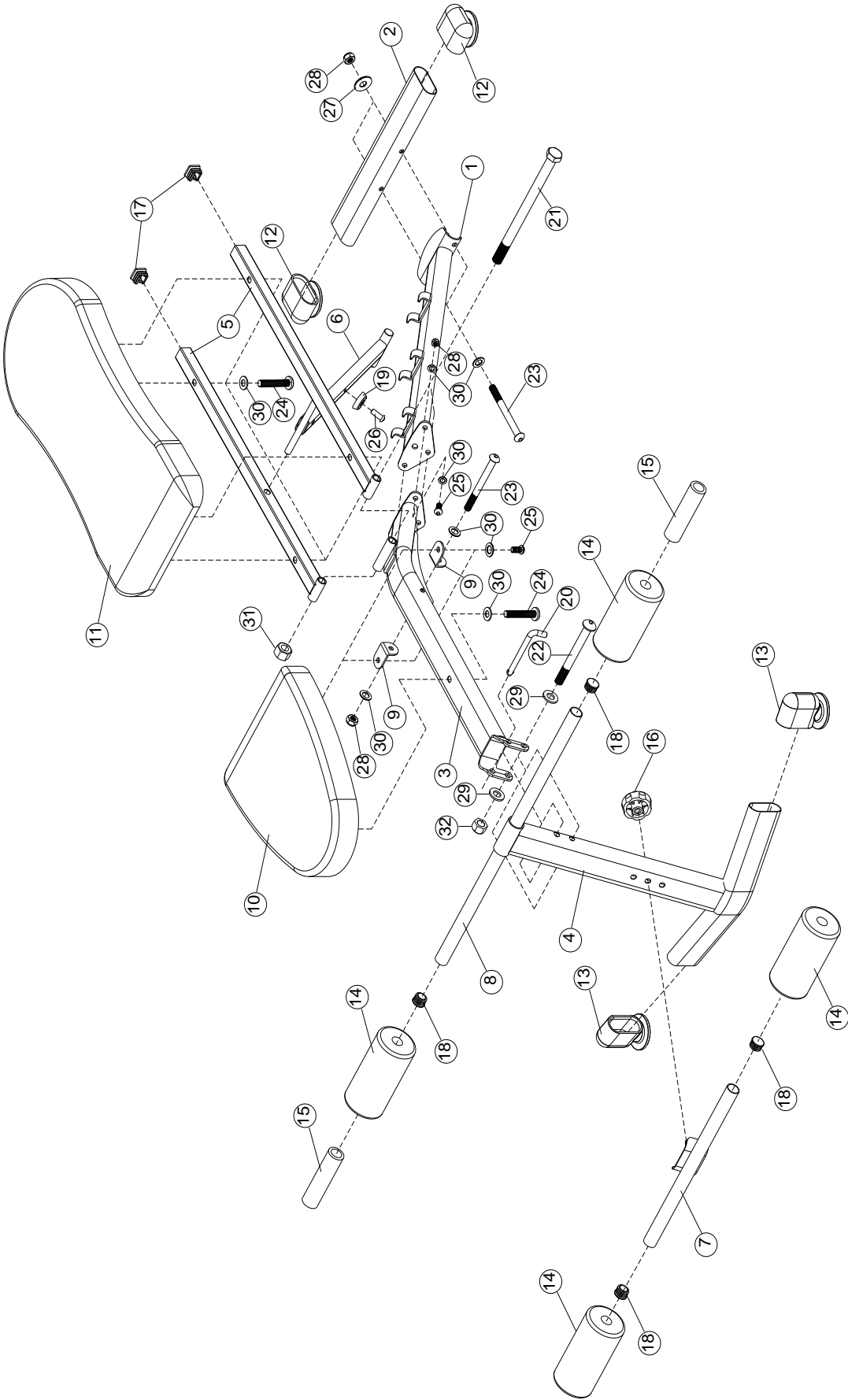

SB-228C PARTS LIST

KEY NO.	DESCRIPTION	Q'ty
1	Lower Main Frame	1
2	Rear Stabilizer	1
3	Main Frame	1
4	Front Vertical Frame	1
5	Backrest Support	2
6	Incline Support	1
7	Cross Tube	1
8	Foam Tube	1
9	L-shaped Bracket	2
10	Seat	1
11	Backrest Board	1
12	Rear Stabilizer End Cap	2
13	Front Stabilizer End Cap	2
14	Vinyl Foam Roll	4
15	Foam Grip	2
16	Lock Knob	1
17	1" Square End Cap	2
18	Ø 1" End Cap	4
19	Rubber Bumper	1
20	L-shaped Lock Pin	1
21	M12 x 6 7/8" Hex Bolt	1
22	M10 x 3 3/4" Allen Bolt	1
23	M8 x 3 3/8" Allen Bolt	3
24	M8 x 1 3/4" Allen Bolt	5
25	M8 x 3/4" Allen Bolt	5
26	M6 x 5/8" Philips Screw	1
27	Ø 3/4" xR1" Washer	2
28	M8 Aircraft Nut	6
29	Ø 3/4" Washer	2
30	Ø 5/8" Washer	17
31	M12 Aircraft Nut	1
32	M10 Aircraft Nut	1

IMPEX[®] INC.

LIMITED WARRANTY

IMPEX Inc. ("IMPEX[®]") warrants this product to be free from defects in workmanship and material, under normal use and service conditions, for a period of two years on the Frame from the date of purchase. This warranty extends only to the original purchaser. IMPEX's obligation under this Warranty is limited to replacing or repairing, at IMPEX's option.

All returns must be pre-authorized by IMPEX. Pre-authorization may be obtained by calling IMPEX Customer Service Department at 1-800-999-8899. All freights on products returned to IMPEX must be prepaid by the customer. This warranty does not extend to any product or damage to a product caused by or attributable to freight damage, abuse, misuse, improper or abnormal usage or repairs not provided by an IMPEX authorized service center or for products used for commercial or rental purposes. No other warranty beyond that specifically set forth above is authorized by IMPEX.

IMPEX is not responsible or liable for indirect, special or consequential damages arising out of or in connection with the use or performance of the product or other damages with respect to any economic loss, loss of property, loss of revenues or profits, loss of enjoyments or use, costs of removal, installation or other consequential damages of whatsoever natures. Some States do not allow the exclusion or limitation of incidental or consequential damages. Accordingly, the above limitation may not apply to you.

The warranty extended hereunder is in lieu of any and all other warranties and any implied warranties of merchantability or fitness for a particular purpose is limited in its scope and duration to the terms set forth herein. Some States do not allow limitations on how long an implied warranty lasts. Accordingly, the above limitation may not apply to you.

This warranty gives you specific legal right. You may also have other rights which vary from State to State. Register online at www.impex-fitness.com.

IMPEX[®] INC.
2801 S. Towne Ave.
Pomona, CA 91766

ORDERING REPLACEMENT PARTS

Replacement parts can be ordered by calling our Customer Service Department toll-free at **1-800-999-8899** during our regular business hours: Monday through Friday, 9 a.m. to 5 p.m. Pacific standard time.

support@impex-fitness.com

When ordering replacement parts, always give the following information.

1. Model
2. Description of Parts
3. Part Number
4. Date of Purchase